



ROBOT  
ACCESSORY

# 3爪平行シールドグリップ 3-jaw Parallel Sealed Gripper NPG series

## 密封構造の防塵・防水仕様 Sealed structure, dustproof and waterproof

- 切削水や粉塵等がかかる、厳しい環境下で使用可能 (IP67)  
Ideal for harsh environments such as cutting fluid and dust (IP67)
- 高い内径把持力により、重量ワークの搬送が可能  
Suitable for heavy work piece by high inner gripping force
- エアパージなしで防塵・防水を実現  
Dustproof and waterproof without air purge



### 仕様表 Specifications

項目 Item  型式 Model	ジョーストローク直径 Jaw Stroke (diameter) (mm)	把持力 (注1) Gripping Force (Note1)			繰返し精度 Repeatability (mm)	本体質量 Mass of products (kg)	流体消費量 (cm <sup>3</sup> /往復) Amount of Air Consumption (cm <sup>3</sup> /Round Trip)	使用空圧力 Working Air Pressure (MPa)	周囲温度 Operating Temperature (°C)
		測定距離 Measurement Distance L (mm)	外径把持 O. D. Gripping (N)	内径把持 I. D. Gripping (N)					
NPG306	12	40	460	900	±0.01	0.5	33.3	0.2~0.8	5~60
NPG308	16	40	1000	1900	±0.01	1.30	68.4	0.2~0.8	5~60
NPG310	20	40	2000	3200	±0.01	2.10	139.7	0.2~0.8	5~60

(注1) 供給空圧力0.6MPaでの値です。

(Note1) Value at supply air pressure 0.6MPa

## 把持力曲線 Gripping force diagram

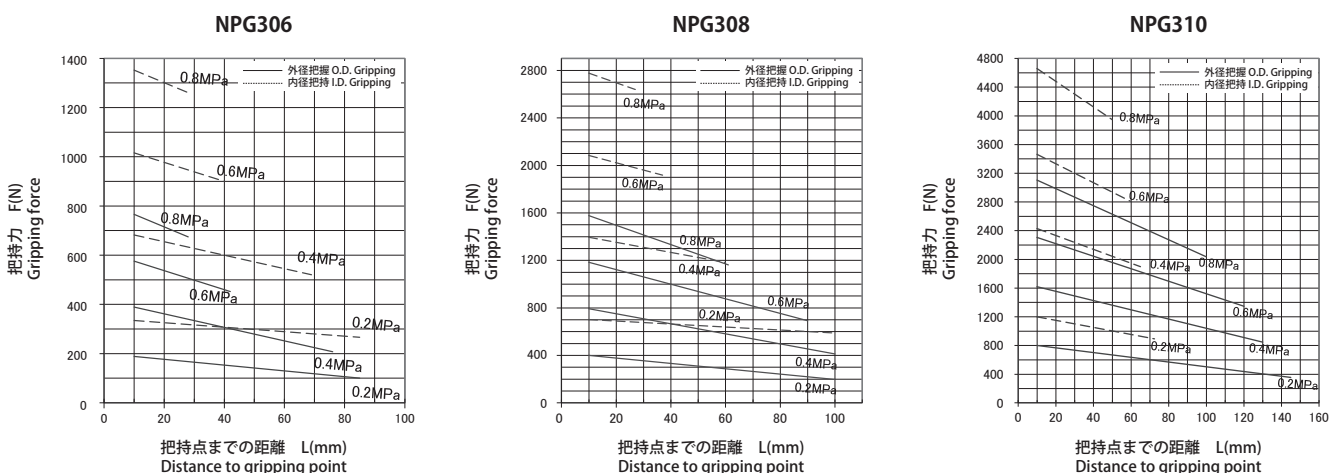

# NPG series

## ■ 寸法図 Dimensions

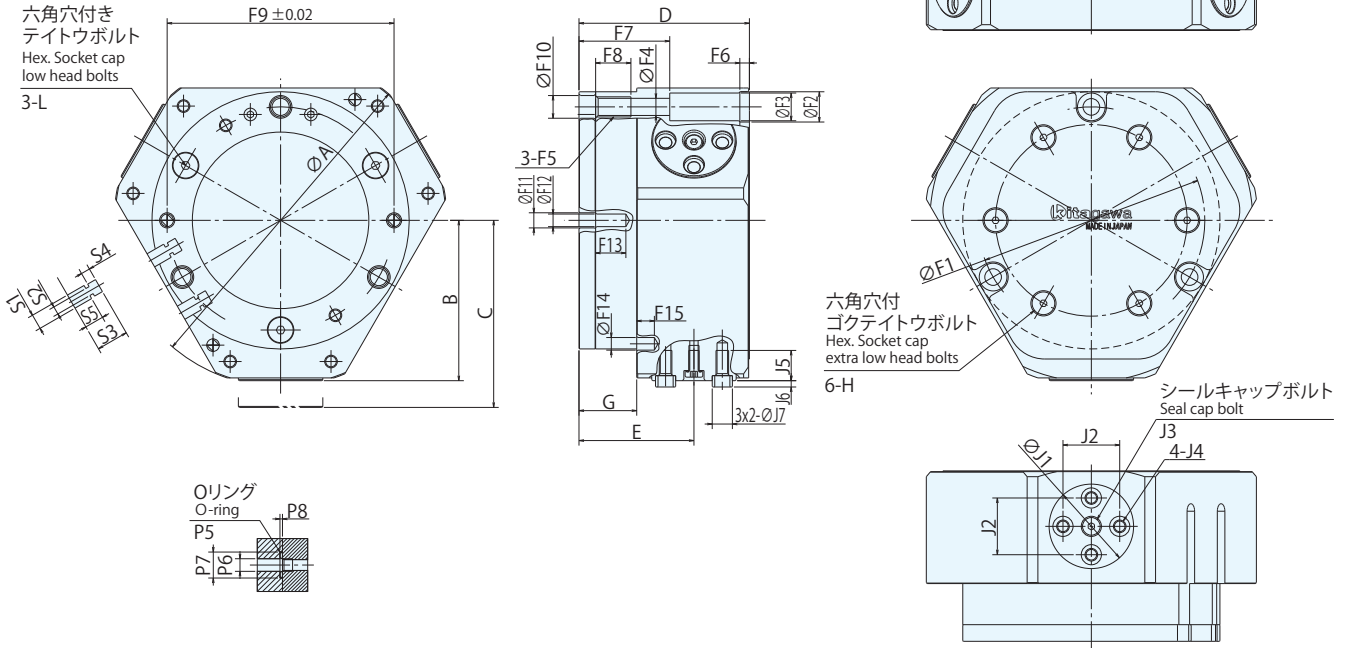

ロボグripper

## ■ 寸法表 Dimensions

型式 Model	外形寸法 Outline Dimensions								ジョー取付け部寸法 Dimensions of Jaw Mounting						
	A	B	C	D	E	G	H	L	J1	J2	J3	J4	J5	J6	J7 径 (h7) Diameter
NPG306	φ 72	34	40	49	32.5	16.8	M5	M4	φ 22.5	15.2	M3	M4	8	2	6
NPG308	φ 110	52.8	61.4	56.8	36.5	15.6	M5	M5	φ 30	20	M4	M5	10	2.5	8
NPG310	φ 132	63.6	74.2	67.6	45.6	22.9	M5	M6	φ 33.5	22.5	M4	M5	12	2.5	8

型式 Model	本体固定部寸法 Dimensions of Body Fixed Part														
	F1	F2	F3	F4	F5	F6	F7	F8	F9 (±0.02)	F10	F11	F12	F13	F14	F15
NPG306	φ 50	φ 9.8	φ 9	φ 5.1	M6	3.8	28	14	50	φ 6.6	φ 5.5	φ 4	8	—	—
NPG308	φ 70	φ 12	φ 11	φ 6.8	M8	3.8	31	14	70	φ 9	φ 6	φ 5	12	φ 4	5
NPG310	φ 90	φ 12	φ 11	φ 6.8	M8	3.8	36	14	90	φ 9	φ 6	φ 5	12	φ 5	7

型式 Model	空圧供給部寸法 Dimensions of Air Supplying Part								スイッチ取付け部寸法 Dimensions of Switch Attaching Part リードスイッチ Reed Switch				
	P1	P2	P3	P4	P5 (NOK規格)	P6	P7	P8	S1	S2	S3	S4	S5
NPG306	M5	M5	24.8	18	S6	φ 4	8.3	1	6	3.2	11.2	3.6	6.1
NPG308	M5	M5	27.3	18	S6	φ 4	8.3	1	6	3.2	14.7	3.6	9.6
NPG310	M5	M5	36.4	24	S8	φ 5	10.3	1	6	3.2	12.7	3.6	7.6